

**Quasar Digital Preset / Totalizer Counter
Operation Manual**



About this Manual

To the best of our knowledge and at the time written, the information contained in this document is technically correct and the procedures accurate and adequate to operate this instrument in compliance with its original advertised specifications.

Notes and Safety Information

This Instruction Manual contains warning headings that alert the user to check for hazardous conditions. These appear throughout this manual where applicable, and are defined below. To ensure the safety of operating performance of this instrument, these instructions must be adhered to.



Warning, refer to accompanying documents.



Caution, risk of electric shock.

Technical Assistance

FSI Technologies Inc. offers assistance Monday through Friday 8:00 am to 4:30 pm Central Time by contacting Technical Support or Customer Service at (630) 932-9380. Internet: <http://www.fsinet.com>

Warranty and Returns

FSI Technologies Inc. warrants each instrument and other articles manufactured by it to be free from defects in material and workmanship under normal use and service, its obligation under this warranty being limited to making good at its factory or other article of equipment which shall within one (1) year after delivery of such instrument or other article of equipment to the original purchaser be returned intact to it, or to one of its authorized service centers, with transportation charges prepaid, and which its examination shall disclose to its satisfaction to have been thus defective; this warranty being expressly in lieu of all other warranties expressed or implied and of all other obligations or liabilities on its part, and FSI Technologies Inc. neither assumes nor authorizes any other persons to assume for it any other liability in connection with the sales of its products.

This warranty shall not apply to any instrument or other article of equipment which shall have been repaired or altered outside the FSI Technologies Inc. factory or authorized service centers, nor which has been subject to misuse, negligence or accident, incorrect wiring by others, or installation or use not in accord with instructions furnished by the manufacturer.

Under the normal field usage there is no need to remove the front bezel of this product. The front bezel of this product should only be removed by a qualified technician.

Menu Category	Parameter Name	Choices / Format	Description	Tech Note
	SP4	000040*	SP4 Set point #2 High. <i>Values:</i> -99999 to 999999. Decimal point will appear according to the current DP setting.	4.5
	rStPo5	000000*	Reset Position Count value is set to this when an Auto or Manual Reset event occurs. <i>Values:</i> -99999 to 999999. Decimal point will appear according to the user-programmed DP position.	4.5
rESEt SEtUP	RrESEt	d:5AbL* Rt SP 1 Rt SP2 Rt SP3 Rt SP4 RftoP 1 RftoP2	Auto Reset Mode Selects when an auto reset function is to occur. Disabled at a set point or after output times out. See also the RSTPOS parameter in the SEtPnt SEtUP category.	4.6

Menu Category	Parameter Name	Choices / Format	Description	Tech Note
	rStbtn	EnAbLE* d:5AbL	Reset Button Enable or disable front panel reset button.	4.7
	PonrSt	no* yES	Power On Reset Select whether count reset event will occur at power-up.	4.7
End			Exit Programming Menu	

* = factory default settings

Menu Category	Parameter Name	Choices / Format	Description	Tech Note
	Ed ← LArCHEd← SP3=L ←	→Ar SP3 →ArSP3* →SP4=H	Output 2 Bindings Reminder message indicates which and how the set points are used for comparison. Which message is displayed is determined by the Output 2 mode selected.	4.4
	dELAY	0 10.00*	Delay 2 Output 2 delay time. <i>Appears only if Output 2 mode set to timed.</i>	4.4
	untL2	rESEt* SP 1 SP2 SP3 SP4 rStPo5	Until 2 Output 2 latched until parameter. <i>Appears only if n n odE2 = LArCH.</i>	4.4

Menu Category	Parameter Name	Choices / Format	Description	Tech Note
SEtPnt SEtUP	SP 1	0000 10*	SP1 Set point #1 Low. <i>Values: -99999 to 999999.</i> Decimal point will appear according to the current DP setting.	4.5
	SP2	000020*	SP2 Set point #1 High. <i>Values: -99999 to 999999.</i> Decimal point will appear according to the current DP setting.	4.5
	SP3	000030*	SP3 Set point #2 Low. <i>Values: -99999 to 999999.</i> Decimal point will appear according to the current DP setting.	4.5

* = factory default settings

Contents

1 Product Description.	3
1.1 General Description.	3
1.2 Part Number Identification.	4
1.3 Option Module Summary.	4
2 Hardware Setup.	5
2.1 Panel Installation.	5
2.2 Removing / Installing Option Modules.	6
2.3 120/240 VAC Power Module.	7
2.4 Standard Input Module.	7
2.5 Quadrature Input Module.	10
2.6 Excitation Module.	11
2.7 Single and Dual Relay Modules.	13
3 Display & Keypad Control.	13
3.1 Display.	13
3.2 Display Error Messages.	14
3.3 What the Keys Do in Display Mode.	15
3.4 What the Keys Do in the Programming Mode.	15
3.5 Special Start-Up Modes.	17
4 Programming Operations and Parameters.	18
4.1 Password and Security Controls.	18
4.2 A/B Channel Options.	20
4.3 Scaling and Decimal Point Position.	21
4.4 Output Control Modes.	23
4.5 Set Point Parameters.	25
4.6 Auto Reset Operation.	26
4.7 Miscellaneous Controls.	27
Appendix A: Technical Specifications.	28
A.1 Functional Specifications.	28
A.2 Electrical, Environmental and Mech.	29
Appendix B: Programming Quick Reference.	31

1 Product Description



1.1 General Description

The Quasar preset counter fits a 1/8 DIN standard cutout and is perfect for tight spaces, extending only 3.24" (82mm) behind the panel. The unit is UL listed. The unit is for indoor use at altitudes up to 2000m, temperatures between 0° and 40°C, and installation category III, pollution degree 2.

The counter is powered from 120 or 240 VAC. The nonvolatile EEPROM retains all programming and count information when power is removed or interrupted.

Display scaling, preset values and all menu functions are easily programmed from the front panel, following easy-to-use word prompts. Front Panel Reset Disable and Password Lockout Protection features guard against unauthorized or accidental changes.

The counter accepts count rates up to 20 KHz and pulses from different types of sensors, including Quadrature, CMOS or TTL circuits and PNP or NPN devices.

The optional, field-replaceable, single/dual relay module enhances the counter from a passive display device to an integral control element for your application. Outputs may be controlled by count values with independent reset operation. The counter has latching, boundary or timed (0.01 to 599.99 seconds) alarm output modes. An optional 12 VDC (100mA) excitation output module can provide power for external sensors.

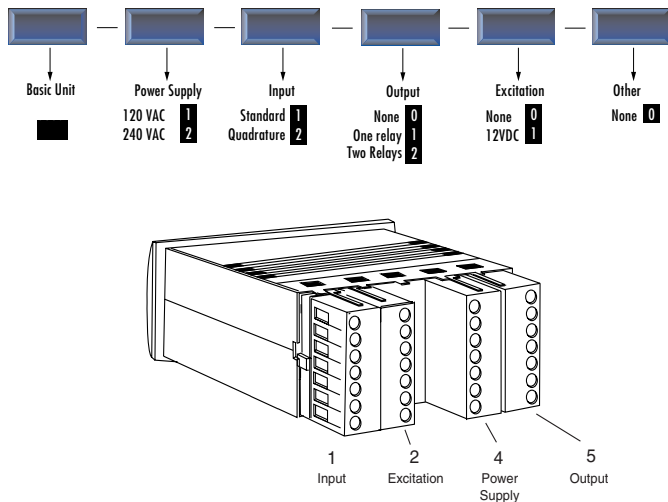

Figure 1. Option Module Slots (Rear View)

Menu Category	Parameter Name	Choices / Format	Description	Tech Note
	dP	000000* 000000. 00000.0 0000.00 000.000 00.0000 0.00000	DP Display Value 1 (Count) Decimal Point location. Affects appearance of RstPos and any associated Set point parameters.	4.3
oPUL 1 SEtUP	n n odE 1	dSAb* bn n Ed LAtCH bound	Output 1 Mode Set the mode of operation for Output 1. Can be disabled, timed, latched or boundary mode.	4.4
	bn n Ed <— LAtCHEd<— SP i=L o <—	—>At SP i —>AtSP i* —>SP2=Hi	Output 1 Bindings Reminder message indicates which and how the set points are used for comparison. Which message is displayed is determined by the Output 1 Mode selected.	4.4

Menu Category	Parameter Name	Choices / Format	Description	Tech Note
	dELAY 1	0 10.00*	Delay 1 Output 1 delay time. <i>Appears only if Output 1 mode set to timed.</i>	4.4
	untL 1	rESEt* SP 1 SP2 SP3 SP4 rStPo5	Until 1 Output 1 latched until parameter. <i>Appears only if n n odE 1 = LAtCH.</i>	4.4
oPUL 2 SEtUP	n n odE2	dSAbL* bn n Ed LAtCH bound	Output 2 Mode Set the mode of operation for Output 2. Can be disabled, timed, latched or boundary mode.	4.4

* = factory default settings

Appendix B: Programming Quick Reference

If you are unfamiliar with navigating menus in the Quasar, see section 3. Each parameter is listed in the order of appearance in the menu system. Refer to the paragraph indicated in the **Tech Note** column for technical details on a particular parameter.

Tip: Photocopy these pages to mark settings on.

Menu Category	Parameter Name	Choices / Format	Description	Tech Note
	PASS	000	Password Entry and Verification	4.1
	ACCESS<—	—>dEnEd	Password Fail <i>Appears if incorrect password entered</i>	4.1
	CHPASS	000*	Password Change <i>Appears if correct password entered</i> 000 = Password protection disabled 001-099 = Secures all parameters 100-999 = Enable SPs/ResPos access in display mode	4.1

Menu Category	Parameter Name	Choices / Format	Description	Tech Note
INPut SETuP	A CHAn	uP* dOb n qUAd r qUAd	Chan A Mode Select count mode of A channel.	4.2
	b CHAn	dir* uP dOb n	Chan B Mode Select count mode for B channel. Note: If A channel set to Quad or Rquad, this item is not accessible.	4.2
Count SETuP	PrESCL	1.0* 0.1 0.01 0.001	Pre-scale Set pre-scaling multiplier.	4.3
	SCALE	0 1.0000*	Scale Set Display Value scaling multiplier. <i>Values: -9.9999 to 99.9999.</i>	4.3

= factory default settings

1.2 Part Number Identification

The following matrix indicates the configuration of your Quasar counter.

1.3 Option Module Summary

The Quasar is a modular product that uses field configuring slide-in modules. The modules slide easily into the rear of the counter.

Figure 1 displays the functional assignments for each module position.

Table 1 describes available option modules for the Quasar.

Table 1. Option Module Summary

Module slot	Type	P/N	Description	See Section
1	Input		Standard Input Module	2.4
1	Input		Quadrature Input Module	2.5
2	Ext	45064	12 VDC Excitation Module	2.6
4	Power		120 VAC Power Module	2.3
4	Power		240 VAC Power Module	2.3
5	Output	45062	Dual Relay Module	2.7
5	Output	45063	Single Relay Module	2.7

A.2 Electrical, Environmental and Mechanical Specifications

Power Requirements	AC Supply: 120 or 240 VAC, $\pm 10\%$
Power Consumption	3VA
Reset Input Signal	Active Low: 0.2 VDC = active
Storage Temperature	-10 to 60°C
Operating Temperature	0° to 40°C
Relative Humidity	0 to 80% for temperatures less than 32°C, decreasing linearly to 50% at 40°C. (Non-condensing)
Bezel	3.93" x 2.04" x 0.52" (99.8 x 51.8 x 13.3mm)
Panel Cutout	3.62" x 1.77" (92 x 45 mm) 1/8 DIN
Case Depth	3.24" (82mm)
Weight	9.0 oz. (255.1 g)

Standard input module

Input Channels	A, B and User
Count edge	High to low transition (A and B channels)
Input Sources	Switch contact, CMOS or TTL logics, PNP or NPN devices
Input Impedance	Sinking: 10K, 5% Res. Pull-up to (9.0 - 16 VDC) $\pm 10\%$ Sourcing: 5.1K, 5% Res. Pull-down to common

Input Thresholds

A & B channels	Low Bias mode: VLT = 1.6V $\pm 10\%$ VUT = 3.6V $\pm 10\%$ High Bias mode: VLT = 5.0V $\pm 10\%$ VUT = 7.0V $\pm 10\%$
User Channel	VLT = 0.2V (min) VUT = 3.0V (max)
Low pass filter	Frequency < 200Hz (0 to 10V input square wave at 50% duty cycle)
Max voltage	A, B and User channels 30VDC maximum sustained

2.2 Removing / Installing Option Modules



Shut power off before removing or installing any option modules



1. Remove module from case by inserting a screwdriver into tab slot opening at top of input module. Apply pressure to release module from case. Repeat procedure for tab located on underside of module and then slide module away from the case.
2. Refer to appropriate sections to configure switches or jumpers for proper operation. Table 1 can be used to identify modules and their associated detail paragraph.
3. Install module by carefully aligning module edges with slots in case and pressing forward until tabs (on top and bottom) engage.

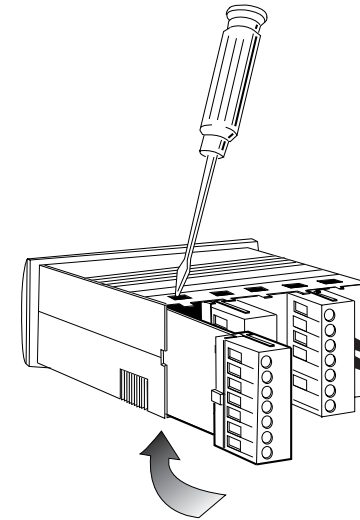

Figure 4. Removing Option Module

2.3 120/240 VAC Power Module



Remove power before wiring option modules.

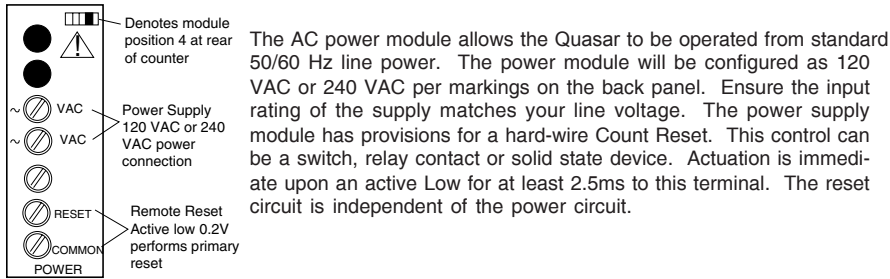

Figure 5. AC Power Module

NOTE: A fusible link is not provided on this module. A ½ Amp Time Delay fuse, Bussman MDL ½, or similar is required.



Never connect AC mains (hot or neutral) to the Reset or Common terminals!

2.4 Standard Input Module

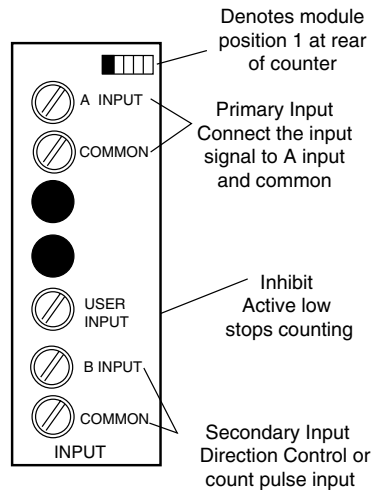

Figure 6. Standard Input Module

A.1 Appendix A: Technical Specifications Functional Specifications

Count modes supported	Count/Direction, Add-Add, Add-Subtract, Subtract-Subtract, Quadrature and Reverse Quadrature
Count Inputs	2: Channel A (Primary) and Channel B (Secondary / Dir control)
Miscellaneous inputs	2: Reset (Count Reset) and User (Count Inhibit).
Count range (internal)	-2,147,483,648 to +2,147,483,648
Maximum count rate	20 KHz (Standard and Quadrature X1 modes) 5 KHz (Quadrature X4 mode)
Min pulse width	5 uS (Standard mode)
Display Digits	6-digit, 7-segment with leading zero blanking
Display Decimal Point	User-programmable
Display LEDs	Red 0.56" (14.2mm), high efficiency
Display Range	- 99,999 to + 999,999 (Independent of decimal position)
Output channels	2, with front panel indicator for each
Output modes	Disabled, Timed, Latching, and Boundary
Delay times	0.01 to 599.99 sec -2.5 ms/+15ms
Output Response time	Latched and timed modes: < 5ms Boundary mode: < 15 ms
Multi-tasking Operation	Count and output control maintained while in programming mode.

4.7 Miscellaneous Controls

r5tbtN (Reset Button)	The Reset Button Inhibit feature disables the front panel reset button. This can be used to prevent accidental resets, especially useful when using the counter as a sequencer. The external (rear panel) hardware reset input is not affected by this setting.
Power5t (Power ON RESET)	When the Power ON RESET is set to YES, the counter will always use the Reset Position value as its initial display/count. With this setting, when an unexpected power loss occurs, the existing count will be lost. When this function is set to NO, the existing count will be retained after a power loss.

- To access the Miscellaneous Controls, enter the Programming Mode, and press ▼ until the r5tbtN menu category is reached.
- Press **ENTER** and then ▼ to continue to the Parameter Name r5tbtN. The display will flash between r5tbtN and the default value of EnAbLE. When the display shows EnAbLE, press.
- Use the arrow keys to select either Enable or Disable. Press **ENTER** when the correct mode is selected to accept selection **ENTER** and proceed to the next parameter name, Power On Reset.
- The display will flash between Power5t and the default nO. When the display shows nO, press **ENTER**.
- Use the arrow keys to select either nO or yES. Press **ENTER** when the correct mode is selected.
- The display will now show End. If you are finished programming the Quasar, press **ENTER**. If not, use the arrow keys to back up to the necessary parameter.

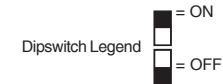
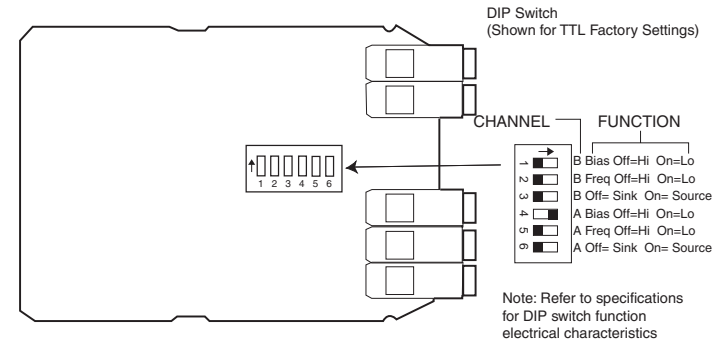

Figure 7. Standard Input Module Default Settings

DIP switch SW1, figure 7, is used to set up the counter to conform to the electrical characteristics of the sensor or signal being detected. Switch positions 1-3 configure channel B, while switches 4-6 configure channel A. These switches select bias (threshold voltages), low pass filter (enable/disable) and sensor type (Sink or Source).

Refer to the documentation that accompanied the sensor for related information. The sensor can most likely be matched to one of the typical switch settings shown in figure 8 and figure 8a.

Note: The input boards are designed so that selecting sourcing or sinking is based on the type of sensor that is being used. If a PNP (sinking) sensor is being used, set the input board for sinking also (switches 3 and 6 = OFF).

If channel B is not used, default settings for switch positions 1 through 3 should be selected. Default settings are provided in Table 2.

The Input module also provides for a user input signal. On the Quasar, this input serves as a count enable/disable control. Connecting User to Common will disable counting.

The Quasar can accept inputs from many different sensors. The A and B channels may be configured independently as shown in Table 2. Figures 8 and 8a have examples of some typical sensors and the wiring connections that would be used.

Table 2. Standard Input Module DIP Switch Settings

* = Factory Default setting

1 B Channel Bias:	OFF = Hi*	$V_{LT} = 5.0\text{ V}$	$V_{UT} = 7.0\text{ V}$	(+/- 10%)
	ON = Low	$V_{LT} = 1.6\text{ V}$	$V_{UT} = 3.6\text{ V}$	(+/- 10%)
2 B Channel Frequency:	OFF = Hi*	(low pass filter disabled)		
	ON = Lo	(low pass filter enabled)		
3 B Channel Sensor:	OFF = Sinking*	(internal pull-up enabled)		
	ON = Source	(internal pull-down enabled)		
4 A Channel Bias:	OFF = Hi	$V_{LT} = 5.0\text{ V}$	$V_{UT} = 7.0\text{ V}$	(+/- 10%)
	ON = Low*	$V_{LT} = 1.6\text{ V}$	$V_{UT} = 3.6\text{ V}$	(+/-10%)

- 5 A Channel Frequency: OFF = Hi* (low pass filter disabled)
ON = Lo (low pass filter enabled)
- 6 A Channel Sensor Type: OFF = Sinking* (internal pull-up enabled)
ON = Source (internal pull-down enabled)

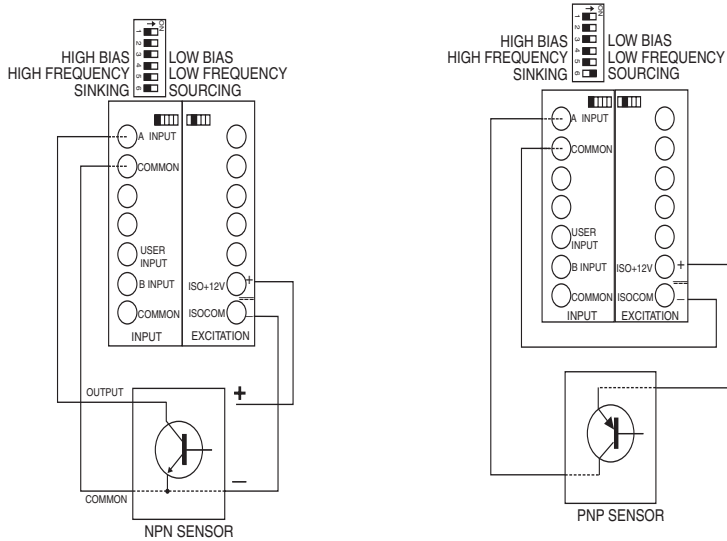

Figure 8. Sensor Connection Examples

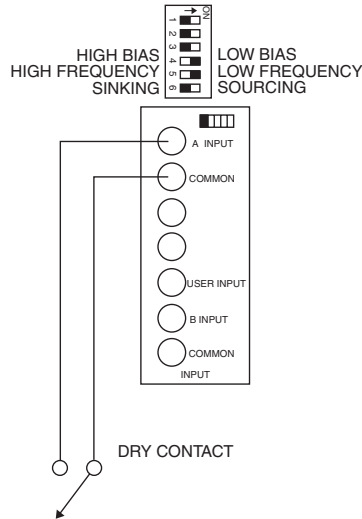

Figure 8a. Sensor Input example

4.6 Auto Reset Operations (Reset Setup)

The Quasar has the capability to perform a Count Reset event based upon various conditions. When Auto Reset occurs, the outputs will return to the deactivated status and the displayed count will return to the value stored in the Reset Position (-5tP05) function. This feature is used in cut-to-length or other applications where an automatic repetitive cycle is established.

There are seven options for the Auto Reset Mode: Disabled, at one of four set points, or after an output times out.

Mode	Description
d5RbL	Only a front panel or external reset event will reset count.
Rt SP	When the selected set point is encountered, reset event occurs.
RftoP 1	Auto Reset occurs after Output 1 times-out (Output 1 must be in timed mode).
RftoP2	Auto Reset occurs after Output 2 times-out (Output 2 must be in timed mode).

- 1) To access the Auto Reset Mode, enter the Programming Mode, and press ▼ until the rE5Et 5Et0P menu category is reached.
- 2) Press ENTER to continue to the Parameter Name R-E5Et. The display will flash between R-E5Et and the default value of d5RbL. When the display shows d5RbL, press ENTER
- 3) Use the arrow keys to scroll through the available options. Press ENTER when the correct mode is selected to accept mode and proceed to the next parameter name, Reset Button.

4.5 Set Point Parameters (Set Point Setup)

The Quasar has four set point parameters and a special value referred to as Reset Position.

The Reset Position can be referred to as Count Reset Value.

SP1 and SP2 are used only with Output 1, and SP3 and SP4 are used only with Output 2.

The SP1 and SP3 parameters are used as Latched or Timed “trigger” values. When a Boundary Output is selected, SP1 and SP3 become the low boundary values.

The SP2 and SP4 parameters are used as high boundary value or ‘turn-off’ values when used with other alarm types (i.e. latched until SP4).

The values for all set points are -99999 to 999999. The decimal point will appear according to the current decimal point setting.

Set Point Parameters

- To set the Set Point parameters, enter the Programming Mode, and press ▼ until the 5E5Pnt 5E5uP menu category is reached.
- Press **ENTER** to continue to the Parameter Name SP 1. The display will flash between SP 1 and the default value of 0000 10. When the display shows 0000 10, press **ENTER**.
- Use the arrow keys to enter the correct value of the flashing digit. Use the **RESET** key to advance to the next digit. Press **ENTER** when the correct set point is selected to accept value and proceed to the next parameter, SP 2.
- Repeat these steps for SP 2, SP 3, and SP 4. The counter will proceed to the next parameter, Reset Position.

Reset Position

- To access the Reset Position parameter, enter the Programming Mode, and press ▼ until the 5E5Pnt 5E5uP menu category is reached.
- Press **ENTER** and then ▼ to continue to the Parameter r5tPo5. The display will flash between r5tPo5 and the default value of 000000. When the display shows 000000, press **ENTER**.
- Use the arrow keys to enter the correct value of the flashing digit. Use the **RESET** key to advance to the next digit. Press **ENTER** when the correct position is selected to accept value and proceed to the next menu category, Reset Setup.

2.5 Quadrature Input Module

The Quadrature / Universal Input Module has two operational modes: Quadrature mode and Standard mode. Quadrature Mode is selected by positioning JP1 and JP2 on pins 1 and 2. Standard Mode is selected by placing JP1 and JP2 on pins 2 and 3 (see Figure 10 for details). The Quadrature mode supports a wide range of encoders including the FSI RSE series.

While in Standard Mode, this module works similarly to the Standard Input module. In addition to the quadrature signal, the quadrature card allows a technician to select a rising or falling edge trigger for the count input signal. The technician is also able to determine the polarity of the user input.

The Input module also provides for a User input signal. On the Quasar, this input serves as a Count Enable/Disable.

NOTE: If B channel is not going to be used, use the default switch settings for SW1 positions 1 through 3. Default settings are provided in Table 3.

In both modes, the state of the user input signal can be selected as active high or active low. DIP switch SW1 configures the counter to match the specifications of the accompanying sensor. When shipped from the factory, the counter is set for X1 quadrature, as shown in Figure 10 and Table 3:

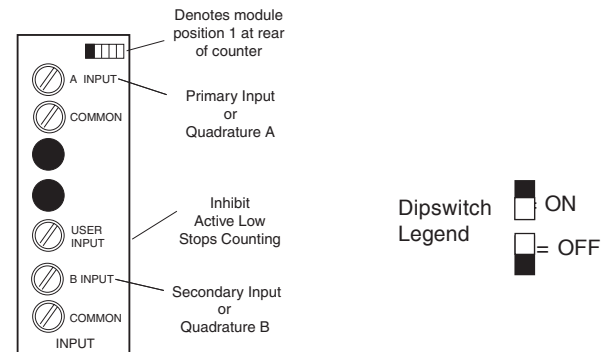

Figure 9. Quadrature / Universal Input Module

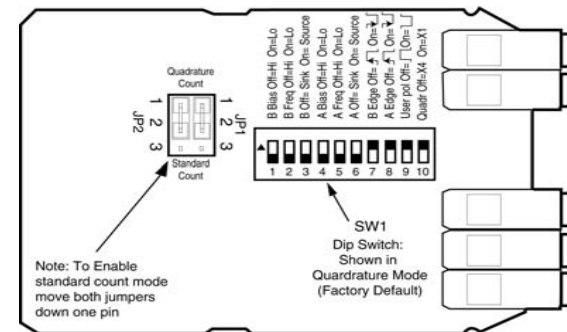

Figure 10. Quadrature Input Module Default Settings

Table 3. Quadrature Module DIP Switch and Jumper Settings

JP1/2: Count Mode Selector

Jumpered 1-2 = Quadrature mode

Jumpered 2-3 = Standard counter mode

SW1: 10 Position DIP Switch

* = Factory Default setting

- 1 B Channel Bias: OFF = Hi* $V_{LT} = 5.0V$ $V_{UT} = 7.0V$ (+/- 10%)
ON = Low $V_{LT} = 1.6V$ $V_{UT} = 3.6V$ (+/- 10%)
- 2 B Channel Frequency: OFF = Hi* (low pass filter disabled)
ON = Low (low pass filter enabled)
- 3 B Channel Sensor: OFF = Sinking* (internal pull-up enabled)
ON = Source (internal pull-down enabled)
- 4 A Channel Bias: OFF = Hi* $V_{LT} = 5.0V$ $V_{UT} = 7.0V$ (+/- 10%)
ON = Low $V_{LT} = 1.6V$ $V_{UT} = 3.6V$ (+/- 10%)
- 5 A Channel Frequency: OFF = Hi* (low pass filter disabled)
ON = Lo (low pass filter enabled)
- 6 A Channel Sensor Type: OFF = Sinking* (internal pull-up enabled)
ON = Source (internal pull-down enabled)
- 7 B Channel Count Edge: OFF = Rising (standard count mode only)
ON = Falling*
- 8 A Channel Count Edge: OFF = Rising (standard count mode only)
ON = Falling*
- 9 User Input Polarity: OFF = High/open circuit = Inhibit Count
ON* = Low/closed circuit = Inhibit Count
- 10 Quadrature Mode: OFF = X4 (quadrature mode only)
ON = X1*

2.6 Excitation Module

**Figure 11. Wiring Encoder w/ Excitation Supply
12 VDC Excitation Module**

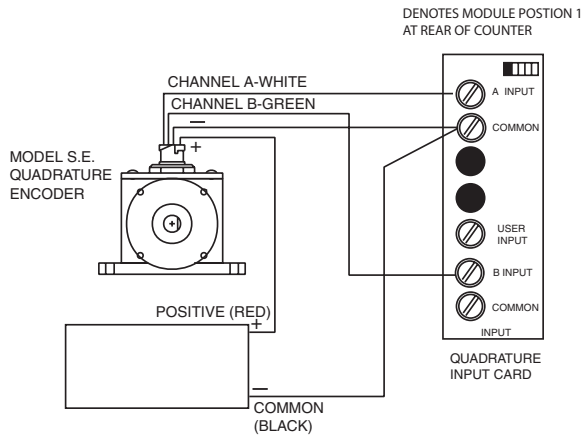

Table 8. Latch Until

Latch Until	Description
Reset	A front panel or external reset event is required to deactivate the output.
SP#	Output deactivated when set point is encountered.
RstPos	Output deactivated when reset position is encountered.

NOTE: The outputs for this counter activate regardless of count direction in all count modes.

- 1) To set the Output Control modes, enter the Programming Mode, and press **▼** until the Output SETUP menu category is reached.
- 2) Press **ENTER** to continue to the Parameter menu. The display will flash between mode and the default value of LATCH. When the display shows LATCH, press **ENTER**.
- 3) Use the arrow keys to select the correct mode. Press **ENTER** when the correct mode is selected to accept value, and proceed to the next parameter, Output 1 Bindings. Other choices may appear, depending on which Output 1 Mode is selected. See Appendix B for which options correspond to which parameters and make selections accordingly.
- 4) Press **ENTER** until Output 2 SETUP is displayed to make similar selections for Output 2 Mode. Again, use Appendix B to make proper selections for subsequent parameters.
- 5) When all selections are entered and accepted into counter memory, counter will proceed to next menu category, Set Point Setup.

4.4 Output Control Modes (Output Setup)

The Quasar supports two independent output channels with four modes of operation: disabled, timed, latched and boundary.

Output Type	Description
Disabled Output	The output channel is inactive.
Timed Output	The timed mode activates an output when a set point or 'trigger' condition is reached. Once active, the output is held for a specified delay period. The delay may be between 0.01 and 599.99 seconds. The output will activate when the specified value is encountered (SP1 for output 1, SP3 for output 2). If a timing period is in progress, a new trigger does not occur. This is referred to as a non-retriggereable timer. A RESET will cancel the timed output.
Latch Output	The latch mode activates an output when a 'trigger' or set point is reached. The output will activate when the value is encountered (SP1 for output 1, SP3 for output 2). Once activated, the output is held and can be deactivated only when the specified Latched Until condition is met. The Latched Until conditions can be seen in Table 8.
Boundary Output	The Boundary mode differs from the other output types in that it allows the counter to have an output activate/deactivate automatically within a specified range. Boundary mode activates an output when the count is between the specified low and high set points (SP1/SP2 for output 1, SP3/SP4 for output 2.)

The Excitation Module can supply 12 VDC at up to 100 mA for external sensors or encoders. This excitation is isolated from the counter internal logic supply. When using sensors or encoders that do not have a signal return or imply a signal return that is in common with the supply voltage, a common attachment that ties the excitation supply to the logic input common may be required. Examples of this appear in figures 8, 8a, 11 and 12.

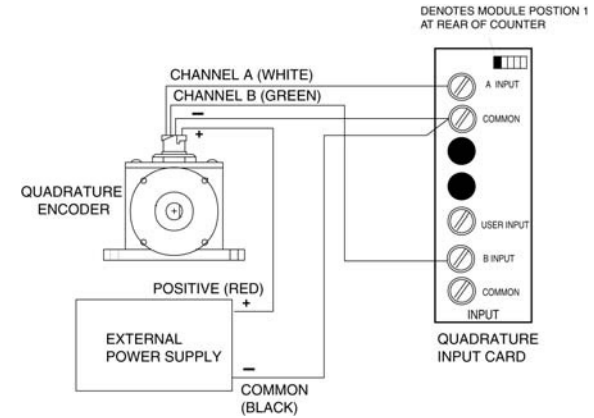

Figure 12. Wiring Encoder with External Supply

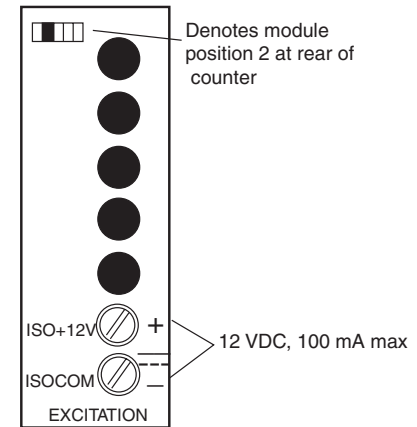

Figure 13. Excitation Module

2.7 Single and Dual Relay Modules

Figure 14 . Single Relay

Figure 15. Dual Relay

The Single and Dual Relay modules can activate circuit loads of up to 5 amps at 250 VAC. A

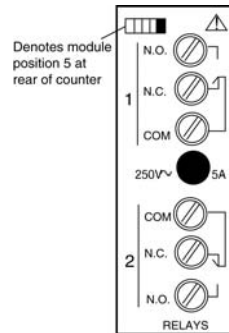
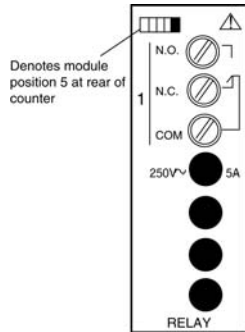

Form C configuration allows use of normally-open (NO) and normally-closed (NC) circuit action.

Only the output 1 channel is implemented in the single relay module.

3 Display & Keypad Controls



Figure 16. Display and Keypad Layout

3.1 Display

- 6-Digit 0.56" high red LED Display.
- 2 Output Status Indicators; "1" and "2."
- Units Window for supplied label or legend.
- 4-Button Keypad with tactile response.

counter and allowing more accurate cutting.

- 1) To access the prescale parameters, enter the Programming Mode, and press ▼ until the count setup menu category is reached.
- 2) Press **ENTER** continue to the Parameter Name prescl. The display will flash between **ENTER** and the default value of 1.0. When the display shows 1.0, press **ENTER**.
- 3) Use the arrow keys to scroll through the choices. Press **ENTER** when correct prescale is selected to accept the value and proceed to the next parameter, Scale.

User-defined Scale

The Quasar also allows for a user-defined scaling multiplier.

- 1) To access the user-defined scaling parameter, enter the Programming Mode, and press ▼ until the count setup menu category is reached. Press **ENTER**.
- 2) Press ▼ to continue to the Parameter Name scale. The display will flash between **ENTER** and the default value of 01.0000. When the display shows 01.0000, press **ENTER**.
- 3) Use the arrow keys to enter the correct value of the flashing digit. Use the key to advance to the next digit. Press **ENTER** when the correct scale is selected to accept value and proceed to the next parameter, Decimal Point.

To calculate the scaling parameter, use the following scale formula:

Display = Multiplier (Pulse x Prescale x Scale x Decimal Point)

If the scale value isn't known, use the following formula:

For the example we used, the scale value is:

$$\text{SCALE} = \frac{\text{DISPLAY} \times \text{DP}}{\text{MULT. (PULSE} \times \text{PRESCALE)}}$$

$$\text{SCALE} = \frac{1.00}{1 (600 \times 0.01)} = 0.1667$$

Decimal Point Position

- 1) To set the Decimal Point position, enter the Programming Mode, and press ▼ until the Count Setup menu is reached. Press **ENTER**.
- 2) Press ▼ to continue to the Parameter Name dP. The display will flash between dP and the default 000000. When the display shows 000000, press **ENTER**.
- 3) Use the arrow keys to scroll through the choices. Press **ENTER** when the correct decimal place is selected to accept value and proceed to the next menu category, Output 1 Setup.

The B channel may be set as Up, Down or Direction. In the direction mode, the B channel is no longer a count source, but controls the count direction of the A channel input. This state control works as an 'exclusive-or' with the channel A direction. Thus, if B input is in the 'Down' state and A channel is set to Down, pulses at the A input will increment count.

Table 7. Count Behavior with B Channel Set as Direction Control

A Channel Setting	State at B Input	Resulting Count
UP	UP	UP
UP	DOWN	DOWN
DOWN	UP	DOWN
DOWN	DOWN	UP

When A channel has been set to either Quadrature or Reverse Quadrature settings, the B channel internally behaves as a direction control.

- 2) To set the B channel:
 - a) In the Input Setup area, after entering the A Chan value, the display will flash between \overline{b} CHAN and the counter's default (d_r).
 - b) When the display shows d_r , press **ENTER**.
 - c) Use the arrow keys to change the value, then press **ENTER** to accept the selection and proceed to the next menu category, Count Setup.

NOTE: The B channel will not show in the menu when Quadrature or Reverse Quadrature has been selected for the A Channel input.

4.3 Scaling and Decimal Point Position (Count Setup)

Prescale

The Quasar counter allows for prescaling of display values. Prescaling allows the counter to display a more accurate number than its 6-digit capacity might otherwise allow by making the positive count the most significant digit.

Generally speaking, the smaller the scale value, the more accurate the count will be. The Quasar has four prescale values, 1.0 (default), 0.1, 0.01, and 0.001.

An example of this application is as follows:

A 600 pulse-per-revolution encoder is used to measure cable before it is cut to the proper length. There is a wheel (one foot in circumference) attached to the encoder, in direct contact with the cable. The user wants to see the counter display feet to 1/100' accuracy (to two decimal points).



With the default prescale of 1.0, one rotation of the wheel would be displayed on the counter as 00.0016'. (1/600, where 1 is the number of feet as shown by wheel rotation and 600 is the number of pulses per revolution.) However, by using a prescale of 0.01, the resolution has been multiplied by 100, allowing the counter to display 0.16667, increasing the accuracy of the

3.2 Display Error Messages

Table 4. Display Error Messages



Display	Description	Action Required
PRdErr	The Keypad is disabled or a key is stuck in the ON position	Cycle power to the counter, if the error remains, return counter to factory for repair.
999999 or -999999 (Flashing)	The displayed count is too large for the counter to display. Since the internal count buffer is much larger than the display, the counter will maintain accurate count and control well beyond the display value.	Reset Counter
E1 (Outputs deactivate, count stops)	Raw Count Overflow: The number of count pulses has exceeded the counter's maximum internal value (2,147,483,648 or -2,147,483,648)	Reset Counter
E2 (Outputs deactivate, count stops)	Math Overflow: A large scale factor in combination with large raw count has exceeded the counter's maximum internal value (+2,147,483,648 or -2,147,483,648)	Reset Counter
E3 (Outputs deactivate, count stops)	Watchdog Fault: The counter did not experience an orderly power-down. This can happen by exceeding the maximum allowable count speed for a sustained period of time.	Reset Counter

3.3 What the Keys Do in Display Mode

Key	Keypad behavior
	Resets count to r5tP05 (Reset Position). This action may be disabled (see section 4.7).
▲ or ▼	Allows quick access to all the set points and r5tP05 (Reset Position). This feature can be disabled by using a password (see section 4.1).
Hold  and Press ▲	Access the Programming Menu.

The up and down keys navigate through the available menu functions. The menu 'wraps around' when the bottom or top of the menu is reached. The up and down key increment or decrement the flashing digit.

3.4 What the Keys Do in the Programming Mode

Key	Keypad behavior
	Select the next digit to the left of the current flashing digit for editing.
▲ or ▼	The up and down keys navigate through the available menu functions. The menu 'wraps around' when the bottom or top of the menu is reached. The up and down keys increment or decrement the flashing digit.
	1) Enter the current menu or parameter to view/edit. 2) Write the change to the counter memory and move to the next function.

4.2 A/B Channel Options (Input Setup)

The next category in the Programming Mode is the "Input Setup." Here you can adjust the A and B channels to the appropriate count modes.

The A channel input may be selected as an Up, Down, Quadrature or Reverse Quadrature* input.

As an Up channel, pulses applied to the A input are added to the display. In Down mode, subtraction occurs. Note that when using Quadrature inputs, appropriate hardware (jumper) settings may be needed.

* The Reverse Quadrature input allows the user to reverse the count direction of the encoder in software instead of having to rewire/remount the encoder.

Table 6. Channel A Selection

A CHAN	Direction	B CHAN
UP	Up	User defined
DOWN	Down	User defined
QUAD	Up	Not Available
R QUAD	Down	Not Available



- 1) To set the A Channel value:
 - a) When the display flashes r nPut 5Et0P, press . The display will change to A CHAN.
 - b) Press  again to proceed to the choice list. Scroll through uP, d0Bn, 9uRd, and r 9uRd using the arrow keys.
 - c) When the selection is complete, press  to accept the selection to counter memory and proceed to the next parameter, Chan B Mode.

Table 5. Password Values

Password Value	Level of Security
000	No Security - Default setting Allows full access to the Programming Menu and Quick Access to set points is enabled.
001 - 099	Fully secure The Programming Menu is secured by password and Quick Access to set points is disabled.
100 - 999	Quick Access Only Programming Menu is secured by password, Quick Access to set points via up and down keys enabled.

- 2) If a password is already in the counter, the display will flash between PR55, for “Enter Password,” and the default value, 000.
 - a) When the display shows 000, press **ENTER**. Use the arrow keys to change the flashing digit to the desired number. Press **RESET** to advance to the next digit.
 - b) Press **ENTER** to enter the password as shown. If an incorrect password is entered, ACCESS dEn Ed will flash on the display. Press an arrow key to return to the PR55 display.
 - c) After entering the correct password, the counter will return to CHPR55. Press **▼** to change the password, or press the **ENTER** key to continue to the Input Setup menu category.

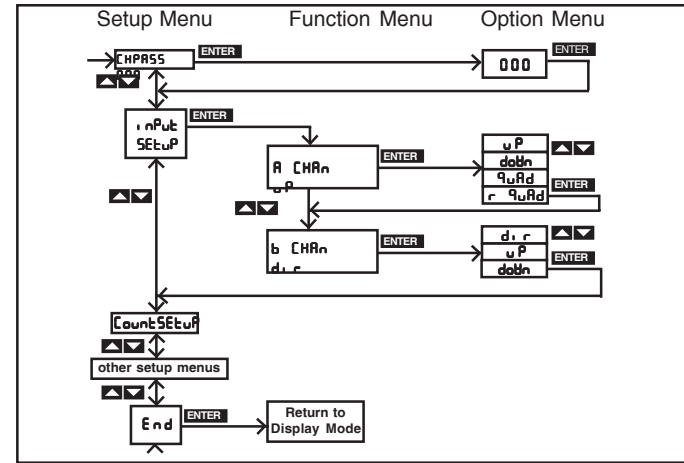

Figure 17. Programming Menu Structure

In the Programming Mode, the Quasar will return to Display Mode automatically if a key is not pressed within 120 seconds (2 minutes). The menu is comprised of three levels: Setup Menu, Function Menu and Option Edit Menu. Figure 17 illustrates the three levels of the menu system.

Password Entry Entry (PR55) and changing of the password (CHPR55) are similar to editing a numerical parameter. See **Numerical Value** below. If the password has been set to a value other than “000,” entry of the proper password is required to access the remainder of the menu.

Setup Menu At the first level of the menu, the arrow keys navigate up or down through the available Menu selections.

Function Menu The second level of the menu contains the functions or software parameters that need to be configured for the counter to operate properly.



Option Menu Contains either Choice Lists or Numerical Values for configuring the functions of the counter.

Choice List A choice list allows selection from a fixed number of options. A Choice List is found in the Options section of the menu. The list is made up of the available options for the function that is being edited. Example: Menu is Input Setup Menu, the Function is A Channel, the Choice List is up, down, quad, and rquad. (See Table 6)

Numerical Value A numerical entry allows the changing of set point values, scale values,

Key	Keypad behavior
▲ or ▼	The up and down keys scroll through the available choices in the Choice list.
	Saves the current choice as new parameter setting and steps to next parameter or category.

etc.



Key	Keypad behavior
	Selects the next digit to the left of the current flashing digit for editing.
▲ or ▼	The up and down keys increment or decrement the flashing digit. Some parameters support negative numbers. In these cases, the most significant digit can be made negative by incrementing it between "9" and "0."
	Saves the values as the new setting for the function in memory and advances to the next function of the menu automatically.

3.5 Special Start up Modes

There are two start-up modes for the Quasar counter. The default start-up mode will be used every time the counter is powered up by the user. There is one alternate start-up mode that will allow the operator to return the counter software functions to factory default settings.

The alternate start-up modes can only be accessed by pressing and holding certain keys during the power up sequence.

- Press and hold both keys on the face of the counter
- Apply power while holding keys

Key	Keypad behavior
 and 	Returns parameters to factory defaults. Resets password to 000, and all user scaling, operation modes and set points to factory defaults. Display will show F-RESEt.

4 Programming Operations and Parameters

This section details the initial programming options of the Quasar, presuming all defaults are in place.

If you are already familiar with the Quasar programming, see Appendix B for the Programming Quick Reference Guide.

To enter the Programming Mode, hold  and press ▲ .



To return to the Display Mode, press  and hold for four seconds when counter is not in an option menu.

4.1 Password and Security Controls

The security feature helps prevent accidental changes to counter settings.

The password value determines the counter's security level, as shown in Table 5.

If you have forgotten the password, see section 3.5; Special Start-Up Modes.

- 1) After entering the Programming Mode, the first field is Password.
 - a) If no password has been assigned, the counter will flash between CHPR55, for "Change Password" and the default value, 000.
 - b) To change the password, press  when the display shows 000. Use the arrow keys to change the flashing digit to the desired number.
 - c) Press  to advance to the next digit. Press to accept the password to counter memory and press it again to advance to the next parameter, Input Setup.