

August 2021

A collection of four different models of FSI encoders is shown in a light gray, semi-transparent style. They vary in size and design, with some having larger output shafts and others having more compact housings. The encoders are arranged in a cluster, with one in the foreground and three behind it.

ORDERING GUIDE

Encoders & Accessories

FSI Technologies Inc.

668 Western Avenue • Lombard, IL 60148-2005

Phone: (630) 932-9380 • Fax: (630) 932-0016

www.fsinet.com
info@fsinet.com

Example

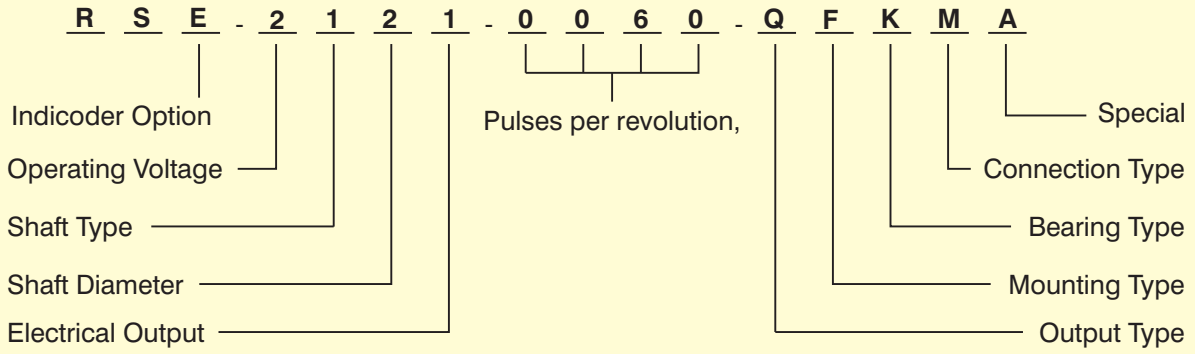

	ESE	RSE	HDE
Family			
ES "ESE" Family (ESE & ESI Prefix)	●	N/A	N/A
RS "RSE" Family (RSE & RSI Prefix)	N/A	●	N/A
HD "HDE" Family (HDE & HDI Prefix)	N/A	N/A	●
Indicoder Option			
E Without Indicoder option	n/c	n/c	n/c
I With Indicoder option	●	●	●
Operating Voltage			
1 5 VDC	●	●	●
2 12 - 28 VDC	n/c	n/c	n/c
3 Special	N/A	Quote	Quote
4 12 - 28 VDC (Supply), 5 VDC (Output)	N/A	●	●
5 4.5 - 14 VDC	N/A	●	●
6 6 - 24 VDC	N/A	●	●
7 9 - 15 VDC	N/A	●	●
8 5 - 28 VDC	●	●	●
Shaft Type			
1 Single ended	n/c	n/c	n/c
2 Double ended	●	●	●
Shaft Diameter			
1 1/4"	N/A	n/c	N/A
2 3/8"	n/c	n/c	n/c
3 5/16"	●	●	●
6 Slotted shaft for screw jacks	N/A	●	●
7 1/2" sleeve on 3/8" single ended shaft	N/A	●	●
8 5/8" sleeve on 3/8" single ended shaft	N/A	●	●
9 3/4" sleeve on 3/8" single ended shaft	N/A	●	●
Previous "4" is included with B-3 option, specify #3			
Previous "5" is included with B-4 option, specify #2			
"●" = Contact FSI for Price.			
NOTE: BOLD TYPE DENOTES COMMON SELECTIONS. Certain options & choices may be incompatible or affect specs.			

Standard Line Counts (PPR)

1	2	3	4	5	6	8	10	12	15	16	18	20	22	25	28	30	32
36	38	39	40	48	50	60	64	66	72	80	92	94	96	98	99	100	102
120	125	127	130	144	150	156	170	180	186	200	216	222	228	240	250	254	256
260	300	314	336	360	375	400	500	508	512	600	625	720	745	750	762	800	900
927	1000	1024	1200	1250	1270	1400	1500	1800	2000	2048	2250	2400	2500				

		ESE	RSE	HDE
Electrical Output				
1	Standard (NPN with pull up resistor)	n/c	n/c	n/c
2	Open Collector NPN	n/c	n/c	n/c
3	PNP with pull down resistor	N/A	n/c	n/c
4	Open Collector PNP	N/A	n/c	n/c
5	8830 TTL differential line driver (5 VDC)*	N/A	S:● Q:●	S:● Q:●
6	88C30 CMOS diff. line driver (5-15 VDC Max)*⊕	N/A	S:● Q:●	S:● Q:●
7	7272 CMOS diff. line driver (12-30 VDC Max)*⊕	N/A	S:● Q:●	S:● Q:●
*Note:	Differential line driver for index pulse	N/A	●	●
8	Red Lion pin-out, standard NPN,4 conductor	●	●	●
9	Red Lion pin-out, open collector NPN, 4 cond.	●	●	●
D	2.2 K ohm P/U, no SR	N/A	n/c	n/c
E	1.5 K ohm P/U, no SR	N/A	n/c	n/c
F	Open collector, no SR	N/A	n/c	n/c
G	Red Lion pin-out & out, 1.5K ohm P/U, no SR	N/A	n/c	n/c
H	Red Lion pin-out & out, op. collector, no SR	N/A	n/c	n/c
J	RS-644 differential line driver (LVDS)	N/A	S:● Q:●	S:● Q:●
⊕Note:	Output voltage is approx. the same as supply voltage			
Pulses Per Revolution (PPR)				
	Over 600 ppr in a Q,D,B, or G Output Type	●	●	●
	1000 ppr or over in an S Output Type	●	●	●
	1000 ppr or over in an Q,D,B or G Output Type	●	●	●
	2000 ppr or over in a Q,D,B or G Output Type	●	●	●
	Special non-standard discs (ppr)	N/A	Quote	Quote
	Other standard ppr's	n/c	n/c	n/c
Output Type				
S	Single Channel	n/c	n/c	n/c
Q	Quadrature	●	●	●
P	Positive going Index Pulse *	N/A	+●	+●
N	Negative going Index Pulse *	S:● Q:●	S:● Q:●	S:● Q:●
Note:	With P and N outputs, also specify S,Q,D,B,G			
D	Count / Direction	N/A	●	●
B	Up / Down Count	N/A	●	●
G	Anti-Jitter, Single Channel Output	N/A	●	●
*Note:	Synonyms: Index Pulse, Reference Pulse, Marker Pulse, or Z Channel			

		ESE	RSE	HDE
Mounting Type				
F	Base flange: w/blind holes front, back & bottom	n/c	n/c	n/c
H	Blind holes: front, back & bottom	n/c	n/c	n/c
Y or B-3	5 PY front flange ⊕ (requires 5/16" shaft)	N/A	●	●
B-1	Sealed Back Plate Cover ⊕	N/A	●	●
B-2	Face Mount Flange ⊕	N/A	●	●
B-4	Series 25 Encoder Mount ⊕ (requires 3/8" shaft)	●	●	●
⊕Note: Used in conjunction with F or H option.				
Bearing Type (Chrome Steel)				
V or None	Precision ABEC 3, film seal, oil lube	Standard	Standard	n/c
T	Precision ABEC 3, Teflon® seal, oil lube	N/A	●	n/c
K	Precision ABEC 3, Teflon® seal, grease lube Previous "W" replaced by "T"	N/A	●	n/c
Connection Style				
C	Water tight plastic connector "C-2" Style	●	●	●
D	FSI DB-9 Style Connector	n/c	n/c	n/c
G	M12 Connector "Euro" Style	●	●	●
M	Military Style Connector MS Series	●	●	●
R-3	3' Built-in Cable, No Connector	n/c	n/c	n/c
R-15	15' Built-in Cable, No Connector	●	●	●
R-X	Custom length Built-in Cable, No Connector	N/A	● per ft.	● per ft.
7	Seven pin MS connector	N/A	●	●
9	Eight position screw terminal strip connector	N/A	●	●
Special Options				
A	High speed 36 kHz (below 1000 ppr)	N/A	S:● Q:●	S:● Q:●
	High speed 36 kHz (1000 ppr + above)	N/A	S:● Q:●	S:● Q:●
E	Enhanced temp. range -35° C to +75° C	N/A	●	●
I	Delete 220Ω (no short circuit protection)	N/A	●	●
J	Replace 220Ω with 100Ω	N/A	●	●
L	Low power (Q to 600 ppr, S to 1200 ppr)	N/A	●	●
	Low power (Q over 600 ppr)	N/A	●	●
2-xxx	Electronic 2X line count (xxx=ms.)	N/A	Quote	Quote

Mating Connectors and Cables

C-1	6 pin MS Series plug, clamp and boot - unassembled	●
C-1F4-15	C-1 plug and 15 ft. of cable, 4 wire - assembled	●
C-1F4-xx	C-1 plug and "xx" ft. of cable - 4 wire assembled	●+*
C-1F6-xx	C-1 plug and "xx" ft. of cable, 6 wire - assembled	●+*
C-1R-xx	C-1 plug / Red Lion pin-out & "xx" ft. cable - assembled	●+*
C-2	C-2 Mating connector	●
C2F-15	C-2 (4pin) and 15 feet of cable - assembled	●
C-2F-xx	C-2 (4 pin) and "xx" feet of cable - assembled	●+*
C-3	7 pin MS Series plug, clamp, and boot - unassembled	●
C-3F-xx	C-3 and "xx" ft. of cable - assembled	●+*
C-4	6 pin MS right angle plug, clamp, & boot - unassembled	●
C-4F4-xx	C-4 and "xx" ft. of cable, 4 wire - assembled	●+*
C-4F6-xx	C-4 and "xx" ft. of cable, 6 wire - assembled	●+*
C-5	10 pin mating plug - unassembled	●
C-5F-xx	C-5 and "xx" ft. of cable - assembled	●+*
C-8	8 pin "C" style mating connector	●
C-8-xx	8 pin "C" style connector with xx ft. of cable	●+*
D-1-15	FSI DB-9 Connector with 15' cable	●
D-1	FSI DB-9 Connector only (soldering skill required)	●
D-1-xx	D-1 Connector and "xx" ft. of cable	●+*
M12-5	5 pin M12 style connector	●
M12-5-4-xx	5 pin M12 style connector and "xx" feet of 4-wire cable - assembled	●+*
M12-5-5-xx	5 pin M12 style connector and "xx" feet of 5-wire cable - assembled	●+*
M12-8	8 pin M12 style connector	●
M12-8-xx	8 pin M12 style connector and "xx" feet of cable - assembled	●+*

Flexicouplings

F-1	1/4" bore flexicoupling	●
F-2	3/8" bore flexicoupling	●
F-3	5/16" bore flexicoupling	●
F-4	General flexicoupling: fits 1/4", 3/8" & 5/16" shafts Use when shafts are not the same size.	●
F-5	1/4" Motor pilot to 1/4", 5/16", or 3/8" bore flexicoupling	●
F-6	3/8" Motor pilot to 1/4", 5/16", or 3/8" bore flexicoupling	●
	F1-F4 Flexicoupling, 1.50" length, 1.00" dia. F5-F6 Motor pilots, 1.25" length, 1.00" dia	
	CEC...Custom encoder couplings 3mm - 40mm in 1mm and 1/16" increments.	●

Mounts

MB-1	Chariot Mounting System	●
------	-------------------------	---

Measuring Wheels (12" Circumference with Scale)

WH-1-A	Measuring wheel / black tire - 83A durometer	●
WH-1-B	Measuring wheel / non-marking tire - 83A durometer	●
WH-1-C	Measuring wheel / non-marking tire - 92A durometer	●
WH-1-D	Measuring wheel / non-marking tire - 70A durometer	●
	All wheels have a 3/8" bore.	
RT-A	Replacement Tire Tread for WH-1-A	●
RT-B	Replacement Tire Tread for WH-1-B	●
RT-C	Replacement Tire Tread for WH-1-C	●

Mating Connector & Cable Selection Examples for ESE, RSE & HDE Encoders

Encoder Connection Style & Code	Encoder Configuration	Connectors with Cables	Connectors
Military / MS ("M")	Single Channel with differential output or index pulse (but not both) Quadrature-with no differential outputs, and no index pulse	C-1F4-xx, C-4F4-xx	C-1, C-4
Military / MS ("M")	Single Channel-with both differential output and index pulse Quadrature-with differential outputs or index pulse (but not both)	C-1F6-xx, C-4F6-xx,	C-1, C-4
Military / MS ("M")	RSE, HDE Quadrature-with both differential outputs and index pulse	C-5F-xx	C-5
Watertight Plastic ("C")	Single Channel Encoders with differential output or index pulse (but not both) RSE, HDE Quadrature-with no differential outputs, and no index pulse	C-2F-xx	C-2
FSIDB-9 ("D")	Single Channel with differential output or index pulse (but not both) Quadrature-with no differential outputs, and no index pulse	D-1F-15 D-1F-xx	D-1
M12 ("E")	Single channel and quadrature, no differential outputs or index pulse Single channel and quadrature, with index pulse. No differential outputs	M12-5-4-xx M12-5-5-xx	M12-5
M12 ("E")	All encoders with differential output	M12-8-xx	M12-8

Tuff-Coder Series Encoders

"The Toughest Encoder ever made" Calculate price of equivalent RSE encoder with standard shaft and mounting, and add ●. Consult Tuff-Coder Brochure for ordering information.

Defender Series Encoders

Calculate price of equivalent RSE encoder with standard shaft and mounting, and add ●. Consult Defender Brochure for ordering information.

Encoder Testing & Repair Services

Standard testing: ●

Adder for thermal and stress testing: ●

Single stage repairs (repair is authorized prior to inspection)

Output type	RSE, RSI, ESE, ESI	HDE, HDI
S	●	●
Q, D, B, G	●	●

Two stage repairs (repair is authorized after inspection)

Output type	RSE, RSI, ESE, ESI	HDE, HDI
S	● + ●	● + ●
Q, D, B, G	● + ●	● + ●

There is no charge if the encoder is deemed to be un-repairable

Counters & Rate Controllers

Quasar Counters

Options

QUA-1122-1111-00
QUA-XXXX-XXXX-00

Quadrature input capability, 2 outputs, and power supply for encoder
Counters with fewer options are available for quantity purchase



FSI TERMS AND CONDITIONS OF SALE AND USE

A WORD ABOUT SAFETY: Most of FSI Technologies Incorporated's products are designed for general and not for specific applications. Because of this, we usually are not aware of and do not control how they eventually will be used. However, they are frequently employed in controlling automatic machinery or processes. Although FSI Technologies Inc. (hereinafter referred to as FSI) makes products of high reliability, every product, given enough time, can be expected to fail. Statistically, devices can fail after a short period of time or a long period of time or anytime in between. In essentially all cases, failure means (1) failure to provide a signal when it should or (2) the providing of such a signal it should be absent or (3) failure to meet some other requirement. But, in all cases, it means to do something unwanted or unexpected. Since the failure of automatic machinery or processes can create hazardous conditions for personnel or property, it is necessary to consider the consequences of device failure and design the application in which the FSI product is used in a fail-safe manner so that failure will not create a hazard to personnel or property, or where the chance of such failure does not cause an unacceptable risk of loss. No guarantee or warranty, expressed or implied, is made as to such effects incidental to such use, handling or possession or the results to be obtained. FSI expressly disclaims responsibility therefore. Furthermore, nothing contained herein shall be construed as a recommendation to use any product in conflict with existing laws, regulations or patents covering any material or use. Warranties of Sale, disclaimer thereof and limitations of liability are covered exclusively by FSI's printed warranty statement for controls. Instructions do not expand, reduce, modify or alter FSI's warranty statement, and no warranty or remedy in favor of a customer or any other person arises out of these instructions.

LIMITED WARRANTY: This limited warranty and remedy is exclusive and expressly in lieu of all other warranties either expressed or implied, either in fact or by operation of law, statutory or otherwise, including but not limited to warranties of design, merchantability and/or fitness for particular use or purpose. FSI does not assume nor authorize any person or facility to assume for FSI any liability in connection with the sale, installation or use of its products. FSI products are not intended for use as final safety devices, or in security applications or in fail-safe applications where bodily harm may be caused. FSI makes no warranty whatsoever in respect to products which have been subject to misuse, neglect or accident, or products that have been modified by others, or products where tamper evident seals have been broken. Any hardware or software modification of the product (except for standard installation, setup and programming) voids the warranty unless / until it is certain that a problem is unrelated to the modification. There is no warranty for compatibility with any product not supplied by FSI. FSI reserves the right to make changes in its products without any obligations to incorporate such changes in any product previously manufactured. FSI warrants that its products sold hereunder will be free from defects in workmanship and/or material under normal use (and shall have no liability for special, incidental, collateral or consequential damages or injury to person or property of any kind from any cause) for a period of 1 year from date of shipping from our factory. FSI in-factory repairs are warranted (under the same conditions) for 90 days against reoccurrence of the same problem. Except for this repair warranty, there is no warranty on services except that the billed-for hours were worked. On FSI Machine Vision solutions, we offer an optional separate Assured Path to Success™ program which is in addition to our warranty. Material may only be returned to FSI upon obtaining (and subject to) a return authorization from FSI. Goods so returned will be repaired or replaced without charge, but FSI shall not be liable for loss, damage or expense directly or indirectly arising out of defective merchandise. In no case will FSI's liability exceed the price of the product or service. Where a product made by another manufacturer is sold as such, the warranty is further limited to their warranty and warranty conditions. This warranty gives you specific legal rights; you may have other rights which vary from state to state. Exclusion or limitation of consequential damages may not apply in states that do not allow such exclusions or limitations.

After initial shipment or pickup, FSI products are ultimately transferred by others to and installed under thousands of different jurisdictions with different requirements, most of which vary with the details of application. FSI makes no claim, implication or statement of knowledge of or compliance with any such requirement except for cases where FSI makes a specific explicit statement of compliance in writing or by marking of the actual product. FSI does support nor agree with any purchase, sale, transportation, installation or

use of any of our products where such action conflicts with any regulations or requirements, or where such imposes additional requirements upon FSI.

Changes in specifications and drawings by the buyer are subject to FSI's acceptance, and the buyer is to reimburse FSI for all costs and materials which cannot be used due to the change in specifications. Tools, dies and the products of other FSI design efforts embody FSI's designs and any charges made for them represent only a portion of their cost. Accordingly, FSI retains the title and all rights to their possession.

Delivery promises are made in good faith but are not guaranteed, FSI shall not be liable for any delay in delivery due to fires, strikes, or other labor disputes, accidents to machinery, acts of sabotage, riots, delays in transportation or lack of transportation facilities, restriction imposed by Federal or State legislation or rules or regulation thereafter, or by any cause beyond the control of FSI.

Orders and individual releases are considered a firm commitment on the part of the Buyer. To cancel or indefinitely or substantially delay all or part of the undelivered balance, it is understood that the Buyer shall be obligated to pay for any partially completed units, special materials which have been purchased for the contract, FSI's direct and overhead expenses incurred, and for any price difference in quantity taken vs. quantity ordered. Buyer agrees to pay such charges within 30 days after such action. FSI shall be entitled, in addition to all other remedies available by law, to recover reasonable attorney fees and/or other expenses in collecting the purchase price or otherwise enforcing or successfully defending itself in respect of this sales contract. Products sold by FSI are not generally returnable due to transaction costs and due to most equipment being built to order, but there are exceptions to this statement.

All contracts involving the sale of merchandise by FSI shall not grant to the Buyer any license or right of any kind under any patent owned or controlled by FSI or under and patent under which FSI had a license, except as a patent license may be specifically granted in writing. All contracts involving the sale of merchandise by FSI must guarantee and protect FSI against infringement of any letters, patents, copyrights, trademarks, or trade names which may arise through application or use of the merchandise.

In the absence of a written acceptance of these conditions by the Purchaser, an acceptance of any goods covered by this order shall constitute acceptance of these conditions, which shall comprise the entire contract between the Purchaser and FSI. FSI's failure to object provisions contained in the Purchaser's order or other communications shall not be deemed a waiver of the terms of conditions hereof. All software and software products are licensed or loaned, not sold. You may not reverse engineer, de-compile or disassemble any software product, or reverse engineer any FSI product. Stenographic and clerical errors are subject to correction. All orders are subject to FSI acceptance at its option. Pricing is based on FSI's standard terms of sale, scope of services, packaging and handling of all specifics. Any additional requirements are subject to explicit acceptance by FSI and additional charges, or, in the absence of such acceptance and charges, they are additional charges later if and when such requirements cause an additional cost to FSI. Terms (with approved credit) for orders under \$5000 are net 30 (payment due before 30 days after shipment date); freight, additional costs associated with export, special handling and special packaging are additional. For orders \$5000 - \$15,000 they are the same except payment schedule is 1/2 to fully proceed and 1/2 net 30. The same applies for orders in excess of \$15,000 except the payment schedule is 1/3 to fully proceed, 1/3 to ship, and 1/3 net 30. Overdue payments are subject to a 1 1/2% per month interest charge plus addition of costs expended for collection of payment. Our minimum billing per customer-defined release is \$100; otherwise it may be waived for a \$20 additional charge. Buyer must guarantee and protect FSI against infringement of any letters, patents, copyrights, trademarks, or trade names which arise from application-related issues of FSI products, or from customer specified Custom Built Merchandise, and indemnify FSI from any resultant claims, suits, or actions. Indemnification shall include costs, expenses, attorney fees, and other expenses.



668 Western Avenue Lombard, IL. 60148-2097

ph: 800-468-6009 fax: 630-932-0016 info@fsinet.com www.fsinet.com

