

# IMPORTANT INSTRUCTIONS

## Model ESE Rotary Shaft Encoder

Made in  
U.S.A.

### FEATURES

- Quadrature Output
- High Noise Immunity
- Short Circuit Protection
- Reverse Polarity Protection
- Input Voltage Range 12-28 VDC
- Sealed Connector
- Gold Plated Connector Contacts
- Double Ended 3/8" S/S Shaft
- Infrared LED and SMD Circuitry
- Heavy Duty ABEC 3 Bearings
- Low Power Consumption

### APPLICATIONS

- Speed Controls
- Robotics
- Machine Tools
- Cut to Length
- Position Control
- Index Tables



### CAUTION

**IMPROPER HANDLING OR  
USE MAY DAMAGE ENCODER**

**Please:**

**Don't exceed the proper operating voltage.**

**Don't tap or pound a fitting onto the shaft.**

**Don't drill holes in the shaft or housing.**

**Don't remove cover plates.**

**Don't attempt to oil or lubricate bearings.**

\* For additional application and technical information please call FSI.



### WARNING

**FSI Products are not intended  
for use as final safety devices.**

Note: Designs incorporating controls of any kind should be carefully considered to provide for their eventual failure.

### SPECIFICATIONS

#### Input

Voltage: 12-28 VDC

Current: 35 ma. @ 15 VDC typical

#### Output

Squarewave 50/50 duty cycle

0 - 10,000 pulses/sec.

\* Please consult factory for details and technical bulletins.

#### Mechanical

Housing: Rugged anodized aluminum

Shaft Rotation: Either direction

Shaft speed: 6000 RPM max. \*

Bearings: Heavy duty ABEC 3

Load: 30 lbs. radial \*

10 lbs. axial \*

**Temperature Range:** 32° - 149° F (0° - 65°C)

### DESCRIPTION

The ESE Series optical shaft encoder represents a major price - performance breakthrough. It utilizes IRED light sources and precision mechanical components to provide long life and durability. Its quadrature output can be used to derive RPM, feet per minute and angular position. When used with simple controls, material can be cut to length and over and under speed conditions detected. The ESE package with its easy mounting and sealed connector is designed to meet the demands of

industry and its price, the goals of the OEM. Over four decades of engineering and manufacturing experience is embodied in every "ESE". FSI is committed to manufacturing quality products and providing complete customer satisfaction!



**FSI Technologies Inc.**

668 Western Ave. • Lombard, IL 60148-2097

(630) 932-9380 • FAX: (630) 932-0016

www.fsinet.com

## ESE SERIES MECHANICAL

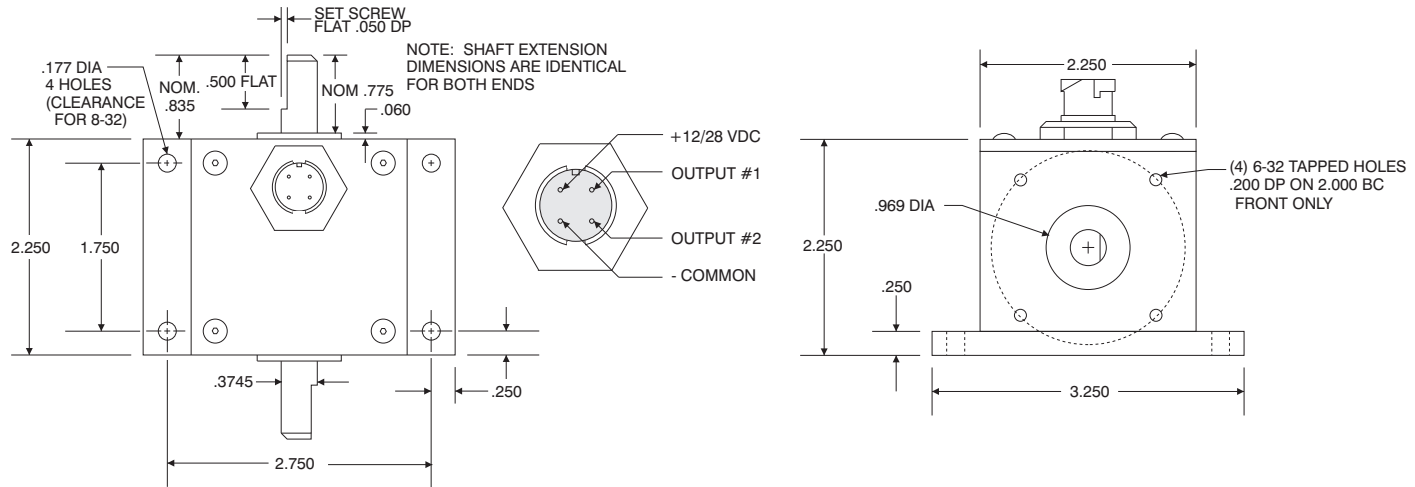

## WIRING INFORMATION

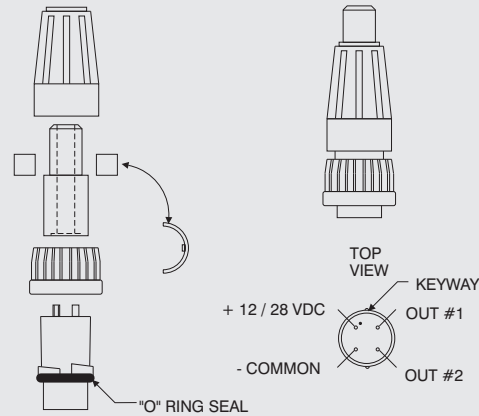
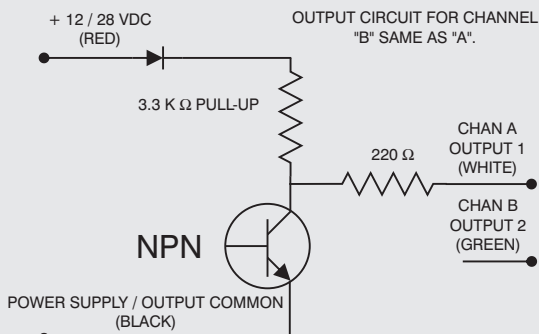

**IMPORTANT NOTICE:** Most of FSI's products are designed for general and not for specific applications. Because of this, we usually are not aware of how they eventually will be used. However, they are frequently employed in controlling automatic machinery or processes.

Although FSI makes products of high reliability, every product, given enough time, can be expected to fail. Statistically, devices can fail after a short period of time or a long period of time or anything in between. In essentially all cases, failure means (1) failure to provide a logic signal or power to an electrical load when it should or (2) the providing of such a signal or power when it should be absent. Less often, failure means failure to meet some other specification. But, in all cases, it means to do something unwanted or unexpected.

Since the failure of automatic machinery or processes can create hazardous conditions for personnel or property, whatever the definition of failure might be, it is necessary to consider the consequences of failure and design the application in which the FSI product is used so that failure will not create a hazard to personnel or property. The design must insure that any failure will result in a fail-safe condition and there will be no danger to personnel and/or property involved in the use of the product. *FSI products are not intended for use as final safety devices.*

**Designs incorporating controls of any kind should be carefully considered to provide for their eventual failure.**

The use of this product is beyond the control of the manufacturer, no guarantee or warranty, expressed or implied, is made as to such effects incidental to such use, handling or possession or the results to be obtained, whether in accordance with the directions of the claimed so to be. The manufacturer expressly disclaims responsibility therefore. Furthermore, nothing contained herein shall be construed as a recommendation to use any product in conflict with existing laws and/or patents covering any material or use.

Warranties of Sale, disclaimer thereof and limitations of liability are covered exclusively by FSI's printed warranty statement for controls. These instructions do not expand, reduce, modify or alter FSI's warranty statement and no warranty or remedy in favor of a customer or any other person arises out of these instructions.

668 Western Avenue Lombard, IL. 60148-2097  
 ph: 800-468-6009 fax: 630-932-0016 e-mail: fsi@fsinet.com